

OPTIMIZATION OF THE CLEARANCE ANGLE IN INDUSTRIAL DISC CHIPPER

MARIUSZ RECZULSKI
TECHNICAL UNIVERSITY OF LODZ, INSTITUTE OF PAPERMAKING
AND PRINTING
LODZ, POLAND

(RECEIVED SEPTEMBER 2017)

ABSTRACT

Wood chips used for chemical pulp must be of relatively uniform size. The penetration of the pulping chemicals and thus the cooking time, is considerably determined by chip length. The clearance angle (pull-in angle) is a significant parameter of the knife positioning in the disc chipper, that affects the length of the chips." In many production plants, this angle is wrong set depending on the diameter of the chipped wood. This causes problems in obtaining the appropriate length of the chips. The disc chipper in one of the industrial plants in Poland was investigated because it produced chips with smaller lengths from the assumed. This also included the numerical calculations to optimize the clearance angle. In the disc chipper, the variability of the clearance angle (α) along the cutting edge of the knife (helical knives) gives the possibility of improving the quality of the wood chips. Simulations to determine the variability of the clearance angle on the radius of the disc of chipper assuming the continuity of cutting wood in the chipper was also performed.

KEYWORDS: Wood chipping, clearance angle, chip formation, length chips, disc chipper.

INTRODUCTION

The chip size and chip quality has important implications on pulp properties, pulp production, and pulp quality, particularly in the kraft pulping. Therefore the industrial plants that have wood chipping process, strive to produce chips of homogenous size and shape. Observations and studies (Reczulski 2015, 2016) have shown that the cause of formation of too small chips is often related to the incorrect operational settings and construction of wood chipper.

The clearance angle is an important parameter of the knife positioning in the disc chipper which has major influence on the chips length is the clearance angle. There is a close relationship between the clearance angle and the chip length (Hartler 1986, 1996).

Many different studies and analytical considerations (Hartler 1986, Hartler 1996, Hellström et al. 2008, Hellström et al. 2009, Uhmeier and Persson, 1997, Abdallah et al. 2011, Smith and Javid 1999) have been made to obtain model that defines the length of the chip during cutting wood in disc chipper. However, the models are designed for ideal working conditions that occur while cutting wood in the laboratory disc chipper. Such laboratory conditions do not completely reflect the conditions in industry.

In mathematical models, the chips length is usually described simply by the distance between the cutting edge and the plane of the disc and by the spout angle (Eq. 1). In industrial practice, this form of description of the chips length is a great simplification.

MATERIAL AND METHODS

The Carthage-Norman disc chipper used in this research was equipped with 15 knives on the disc having 2640 mm in diameter. The clearance angle for all the knives in the chipper was 3° . The power of the motor is 1600 kW. The revolutions on the outlet shaft are $n = 375 \text{ min}^{-1}$ without loading. The chipper has a gravity discharge of chips. In fact, the diameter of the chipping wood was usually between 120 and 160 mm. The other basic design parameters of this chipper are shown in Tab. 2. The required chip length is 30 mm. Matlab/Simulink to optimize the clearance angle was used. Simulations to determine the variability of the clearance angle on the radius of the disc of chipper were also made. The variability of the clearance angle α along the cutting edge of the knife is the key to obtain chips of the same length.

RESULTS AND DISCUSSION

The clearance angle (pull-in angle- α) has a major influence on the feed rate of wood logs into the disc chipper. Properly selected feed rate of wood for a specific geometry of the cutting zone of the chipper, determines the quality of the chips, ie. dimensional uniformity, mainly in terms of the length of chips.

The optimal wood cutting process occurs if there is a continuity of cut logs i.e. at anytime at least one knife is in the cutting zone. Fig. 1 shows the geometrical relationship in the cutting zone of this chipper.

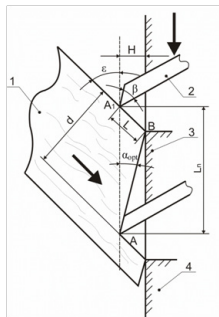

Fig. 1: The cutting parameters of the disc chipper, 1 - log, 2 - knife, 3 - chipper disc, 4 - anvil, (α_{opt} - optimum clearance angle (pull-in angle), L - chip length, H - knife height, ε - spout angle, β - edge angle).

As illustrated schematically (Fig. 1), the chip length can be determined from a simple relationship:

$$L = H/\sin\varepsilon \tag{1}$$

where: H – heights of each knives protruding from a disk surface,
 ε – spout angle.

From Eq. 1 it follows, that the chip length can be controlled only by the height of the knives protruding from a disk surface H , since the spout angle ε is a constant design parameter of the chipper. Such calculation of the chips length is very simple, but impractical for a disc chipper working in the industry.

A better solution to calculate the chips length produced in the industrial wood chipper is to use the following relationship:

$$\alpha = \arctg \frac{L \cdot \sin\varepsilon}{2 \cdot R_c \cdot \sin \frac{\pi}{z} - L \cdot \cos\varepsilon} \tag{2}$$

where: α - clearance angle ($^\circ$)
 L - length of wood chips (mm),
 ε - spout angle ($^\circ$),
 R_c - cutting radius, ie. the distance between the axis of the disc and the considered point of contact between the knife cutting edge and wood log (mm),
 z - number of knives in the disc chipper.

Then the chips length depends on the clearance angle (pull-in angle), spout angle, number of knives in the disc chipper and cutting radius R_c . The number of knives and spout angle are constant parameters that depend on the design of the chipper. Thus the influential parameters of chips length, are in this case: the clearance angle α and the cutting radius R_c .

Eq. 1 determines the optimal value of the clearance angle α_{opt} for chips of a desired length L (wood is in contact with the disc chipper at the point B – Fig. 1). The industrial practice, have shown that only in a few cases the process of continuous cutting is ensured.

The Fig. 2 and Fig. 3 show the different cases for the position of wood relative to the knives and disc, and depending on the applied clearance angles α (pull-in angle).

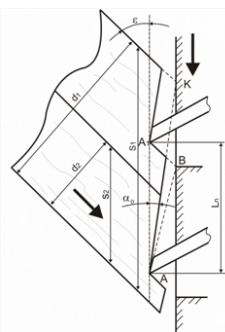

Fig. 2: The illustration of cutting action in wood chipper when clearance angle is lower than optimal ($\alpha_0 < \alpha_{opt}$).

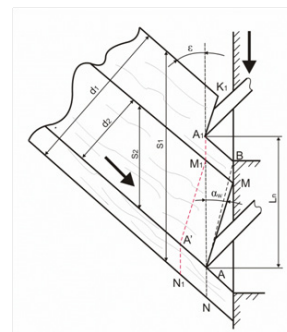

Fig. 3: The illustration of cutting action in wood chipper when clearance angle is higher than optimal ($\alpha_{wb} > \alpha_{opt}$).

Considering the case where the clearance angle (described as α_0 - Fig. 2.), is smaller than the optimum value α_{opt} and the diameter of the wood - d_1 is greater than the distance between the knives - L_n ($d_1 > L_n$), then the contact point of the wood with the disc of the chipper will not be at the point B, but the above - in point K. In this case, the cutting of wood occurs before the log make any contact with the disc, and the chip length is smaller than a predetermined value A1B1 (fines). The chipping of logs by using the lower values of the angle, α_0 leads to production of significant amount of too small chips (pins and fines).

In the case when $d_2 < L_n$, disruption the continuity of cutting wood occurs. The following knife enters the wood only after the exit of the previous knife. In that case, when knife leaves the cutting area, free movement of wood occurs.

In addition, while chipping log with such applied angles, the bounce of wood from the disc occurs. This causes formation of chips with different sizes and micro-cracks in wood, which consequently leads to the weakening and cracking of the chips. Chips are also damaged by the compression forces when the knife hits the log.

Researches carried out by Hartler (1996) for the case $d_2 < L_n$, showed that the actual chip lengths were much smaller than the calculated length.

In the case where the clearance angle (described as α_w - Fig. 3), is greater than the optimum value α_{opt} , - wood log will come into contact with the disc of the chipper at a point M, which is below the point B. Assuming that $d_1 > L_n$, the cutting line of wood is curve defined by the points K1A1M1A'N1. In this case, there is a continuity in cutting of wood and the chips length should be equal to the estimated length. However, in practice, the chips of different sizes are usually produced.

When the actual pull-in angle is greater than the calculated value, wood comes into contact too early with the face plate (point M) and the chips will be deformed or will be longer than a predetermined value L (depending from the design of the disc).

In the case where $d_2 < L_n$, then wood has the ability to bounce after hitting the disc.

Too large values of the clearance angle α are causing the strong pull-in of the wood. The chipping of logs with high values of the clearance angles causes:

- production of large amounts pins and fines
- strong crushing and cracking of wood

This causes formation of chips with different sizes and micro-cracks in wood and consequently the weakening and cracking of the formed chip. Chips are also damaged by the compression forces when the knife hits the log.

The clearance angle α_w (Fig. 3) is defined by the following relation:

$$\alpha_w = \arctg \frac{L \cdot \sin^2 \varepsilon}{d - L \cdot \sin \varepsilon \cdot \cos \varepsilon} \quad (3)$$

where: d - diameter of wood (mm).

The value of the angle α_0 (Fig. 2) can be calculated from the equation:

$$\alpha_0 = \arctg \frac{L \cdot \sin \varepsilon}{2 \cdot R_c \cdot \sin \frac{\pi}{z}} \quad (4)$$

Researches carried out by Hartler (1996) have shown that for a given clearance angle, the actual chips length was smaller than the calculated length. Thus, the optimum angle α_{opt} should be determined from the following relationship:

$$\alpha_{opt} = \arctg \frac{L \cdot \sin \varepsilon}{2 \cdot R_c \cdot \sin \frac{\pi}{z} - L \cdot \cos \varepsilon} + (0,5 \div 1^{\circ}) \quad (5)$$

The Eq. 5 shows that the optimum value of the angle α_{opt} depends on the predetermined length of chips L and cutting radius R_c . The R_c is a value variable in time, and it depends on the diameter of wood and its position in the spout. Therefore, along the length of knife, the clearance angle should be variable. In practice this is difficult to achieve, and so often used is a constant angle α calculated from the average cutting radius.

R_c is often assumed to be the average value of the distance from the axis of the disc to the center of the cutting edges of the knives (R_n -Fig. 4).

For the α set according to previous assumption ($R_c = R_n$) chips are cut in the proper length L only on the radius R_n ie. through the central zone of the cutting edges of the knives. For the radius less than R_n (closer to the center of the disc), the chips are cut in lengths shorter than L , while for the radius greater than R_n (closer to the circumference of the disc), the chips are longer than a predetermined value L .

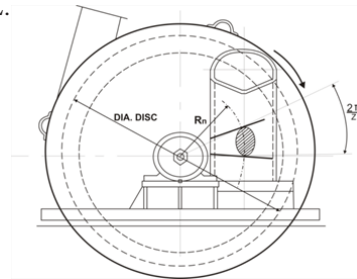

Fig. 4: The illustration of the cutting plane in disc chipper Carthage – Norman, showing the disc diameter and the cutting section of log positioned at the average cutting radius.

To determine the radius R_c , which is variable parameter during cutting, it is necessary to know the diameter of the log and its position in the spout and the design parameters of the chipper.

Fig. 5 shows the possibility of positioning of the log in the spout of the studied disc chipper Carthage-Norman. In this way the analytically values R_{cmin} and R_{cmax} were calculated. The values of these parameters are respectively: 330 mm, 920 mm.

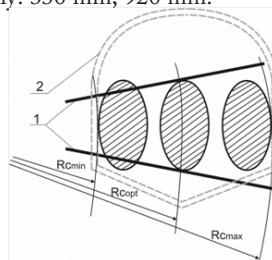

Fig. 5: The scheme of the log positioning in the spout of disc chipper Carthage – Norman
1 - cutting edges of the knives, 2 - outline of the spout.

The discontinuity in cutting may cause the bouncing of logs from the disc of the chipper. This causes the formation of micro-cracks in wood, which may lead to the cracking of the wood chips produced in such conditions.

Tab. 1. The distribution of chipping wood according to its average diameter.

Average log diameter (mm)	<120	120-140	140-160	>160
Logs quantity ratio (%)	10	49	36	5

The continuity of cutting wood in disc chipper has a great influence on the quality of the wood chips. Fig. 6 shows the theoretical extreme case where there is continuity of cutting wood. The figure shows the suitable ellipses of the cutting section in wood logs depending on the location of the log in spout. Dimensions b_1 and b_2 of these ellipses in this type of chipper correspond approximately to the diameters of the wood log. Dimensions s_1 and s_2 can be estimated from the following relation:

$$s = \frac{d}{\sin \varepsilon} \tag{6}$$

where: d - diameter of wood (mm),
 ε - spout angle ($^\circ$).

For dimensions s_1 and s_2 , calculated according to the chipper design parameters, the wood diameters d_{min} and d_{max} were 150 and 450 mm respectively.

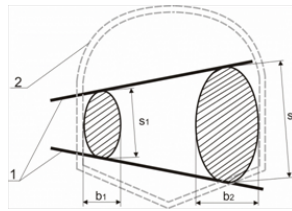

Fig. 6: The scheme of possible positioning of the log on the disc while maintaining the continuity of cutting wood, 1 - cutting edges of the knives, 2 – outline of the spout.

The model in Matlab/Simulink for the computation of the optimum clearance angle (α) for cutting radius $Rc_{min} < Rc < Rc_{max}$, was used (Fig. 7).

The chip length (L), cutting radius (Rc), spout angle (ε), log diameter (d) and the number of knives on the disk are used as the input parameters (Tab. 2) in Matlab/Simulink models (Fig. 7).

Tab. 2: Characteristic input parameters.

Parameters	Range
Cutting radius Rc (mm)	330-920
Chip length L (mm)	30
Spout angle ε ($^\circ$)	38
Log diameter d (mm)	120-160
Number of knives z	15

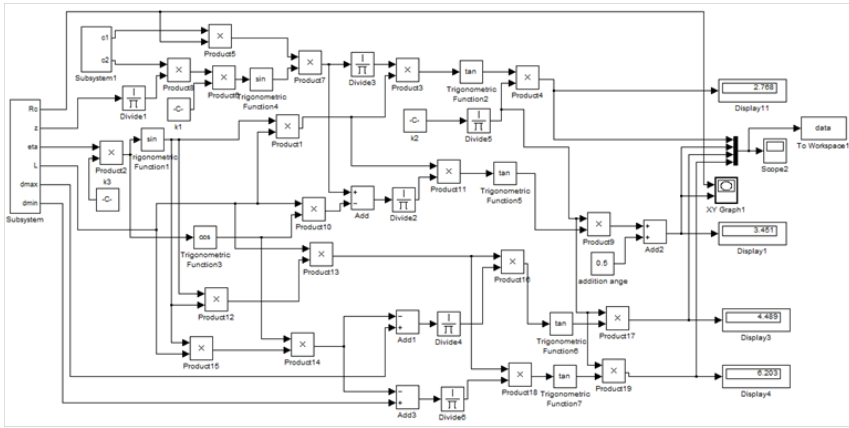

Fig. 7: Panel subsystem block diagram.

The optimum clearance angle for cut wood of 120-160 mm in diameter was determined using a numerical model. Simulations to determine the variability of the clearance angle on the radius of the disc of chipper were also made. The model outputs are shown in Fig. 8 and Fig. 9.

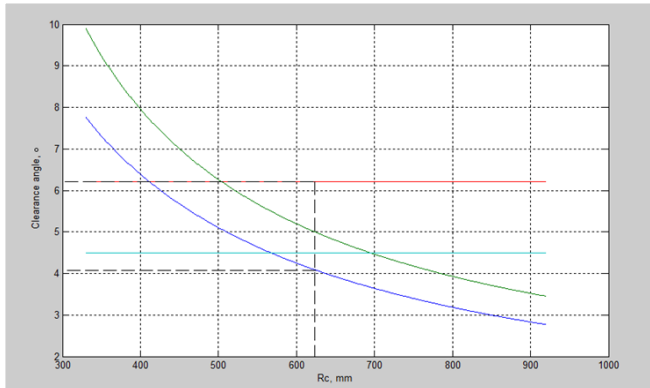

Fig. 8: The simulation results of the clearance angle (α) in relation to the logs diameters, ranging from 120 to 160 mm. α_0 - clearance angle - lower than optimal ($\alpha_0 < \alpha_{opt}$), α_w - clearance angle - higher than optimal ($\alpha_w > \alpha_{opt}$) Calculated for the wood diameter d_{min} (α_{wmin}) and d_{max} (α_{wmax}).

Analyzing all of the possible wood position cases relative to the knives and disc, depending on the applied clearance angles, it was found that the angle α from 4.1 to 6.2° for $R_c = 625$ mm is the most favorable. The clearance angle α_{wmin} was calculated for the wood diameter $d_{min} = 120$ mm and α_{wmax} for $d_{max} = 160$ mm.

The variability of the clearance angle α along the cutting edge of the knife is the key to obtain chips of the same length. This value should decrease in the direction from the center of the disc to its circumference. Fig. 9 shows the variability of the clearance angle along the cutting edge of the knife for chips length $L = 30$ mm. This is the optimum angle value, assuming that there is a continuity of cutting wood along the cutting edge of the whole knife (see Fig. 6).

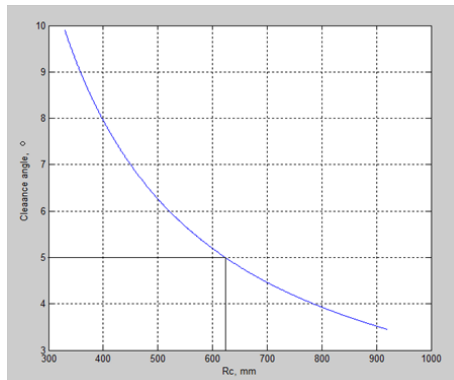

Fig. 9: The variability of the optimal clearance angle (α_{opt}), (Eq. 5) in relation to the disc radius of the chipper.

According to Fig. 9, the clearance angle along the cutting edge of the knife should be between 3.5 to 9.9° to obtain chips length of equal 30 mm. Many industrial plants have difficulty in obtaining variability of the clearance angle along the cutting edge of the knife. The reason is the technical problem. For this case, the clearance angle calculated for the average cutting radius R_c should be used.

According to Eq. 5, (Fig. 9) for the chip length of 30 mm and for the average cutting radius $R_n = 625$ mm, the clearance angle along the cutting edge of the knife should be 5° .

CONCLUSIONS

On the basis of measurements and observations, it was found that the main cause of poor length chips in the studied wood chipper was the wrong clearance angle and too small diameter of the chipped wood.

The results of the simulation show that to obtain a larger number of 30 mm long chips for the existing raw wood material, i.e. the logs with a diameter of 120 - 160 mm, the clearance angle in the disc chipper should be between 4.1 and 6.2° . The angle α is now 3° .

During the chipping of the wood, in order to achieve the optimum cutting conditions, variability of the clearance angle along the cutting edge of the knife should be used. In the studied chipper, variability of the clearance angle can be obtained by changing the edge angle β along the knife.

In order to maintain the continuity of wood cutting in the tested disc chipper and additionally to improve quality of the obtained wood chips, it is necessary to use wood with a diameter of 150 - 450 mm. Feeding of thin and single logs to the chipper should not take place. The uniformity of chips length produced by a disc chipper is a key factor for the increase of i.a. pulping performance.

REFERENCES

1. Reczulski, M., 2015: Analysis of the construction and operation of system wood chipping and transfer chips, *Wood Research* 60(4): 671-678.
2. Reczulski, M., 2016: The system wood chipping in disc chipper – problems of uniformity of chips length, *Wood Research* 61(3): 433-442.
3. Hartler, N., 1986: Chipper design and operation for optimum chip quality, *Tappi Journal* 69(10): 62-66.
4. Hartler, N., 1996: Achievement and significance of optimal chip quality, *Tappi Journal* 79(2): 259-264.
5. Hellström, L., Gradin, P., Carlberg, T., 2008: A method for experimental investigation of the wood chipping process, *Nordic Pulp & Paper Research Journal* 23(3): 339-342.
6. Hellström, L.M., Isaksson, P., Gradin, P.A., Eriksson, K., 2009: An Analytical and Numerical Study of some Aspects of the Wood Chipping Process, *Nordic Pulp & Paper Research Journal* 24(2): 225-230.
7. Uhmeier, A., Persson, K., 1997: Numerical analysis of wood chipping, *Holzforschung* 51(1): 83.
8. Abdallah, R., Auchet, S., Méausoone, P. J., 2011: Experimental study about the effects of disc chipper settings on the distribution of wood chip size, *Biomass and Bioenergy* 35(2): 843-852.
9. Smith, D., Javid S. R., 1999: Proper selection of chipper design and operating parameters can improve both woodyard and kraft pulp mill performance, *Pulp & Paper Magazine* (7).

MARIUSZ RECZULSKI*
TECHNICAL UNIVERSITY OF LODZ
INSTITUTE OF PAPERMAKING AND PRINTING
223 WÓLCZAŃSKA ST.
90-924 LODZ
POLAND
Corresponding author: mariusz.reczulski@p.lodz.pl
PHONE.: +48 42 6313831

